



LED

jetCURE LED

jetCURE LED S
with cooling air outlet at one side

jetCURE LED T
with cooling air outlet at both sides

System-Features

- High irradiation power
- Different wavelengths
- length depends on application
- Light aperture 20 mm or 40 mm
- Continuous power control

Advantages

- Air cooling
- Low weight
- Low temperature load
- Low power consumption
- No warm-up phase
- Ozone-free
- Long service life

jetCURE LED

The **jetCURE LED** is a high-performance array for intermediate curing (pinning) and final curing in printing applications. Other applications are the curing of varnishes, adhesives and pottings.

The jetCURE LED is available in **two versions** which differ in their cooling air duct:

jetCURE LED T has got a cooling air outlet on both sides of the housing. The exhaust air is discharged to the top.

jetCURE LED S has got an one-sided cooling air outlet. The exhaust air is discharged sideways.

Both versions allow a modular (grid: 41 mm) and continuous power control. The **jetCURE LED** is available in the wavelengths 365, 385, 395 and 405 nm +/- 10 nm.

Advantages of LED technology

The typical LED service life is more than 20.000 hours*. The LEDs can be switched-on and -off as often as required without any warm-up or cooling phase and enable cyclic operation.

LEDs do not emit infrared irradiation. Thus they generate only low temperature load on the substrate so that even heat-sensitive materials can be irradiated.

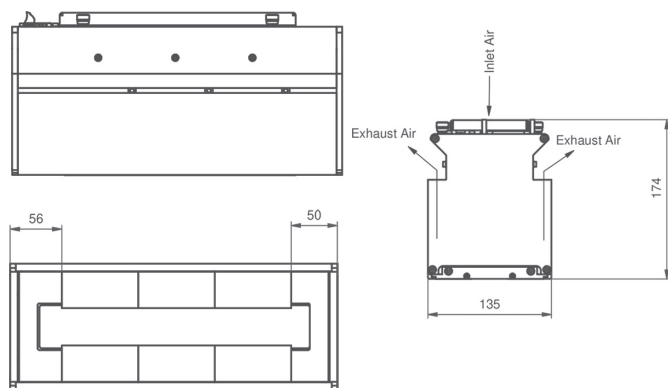

jetCURE LED T with cooling air outlet at both sides

Special Features

- Digital PLC interface
- Serial RS422 interface
- Supply voltage: 48 - 55 V DC
- Power control max. 5 - 100 % (device dependent)
- Integrated air cooling
- Integrated diagnostics function
- Cyclic operation in the milliseconds range possible

Technical Data

| | | | | |
|---|--|-----|-----|-----|
| LED service life | > 20.000 hours * | | | |
| Cooling | Air cooled | | | |
| Irradiated area / Light aperture in mm: | 82 - 656 x 20 82 - 492 x 40 other lengths in 41mm grid steps | | | |
| Wavelengths in nm Intensity in mW/cm ² ** | 20 mm version: | | | |
| | 365 | 385 | 395 | 405 |
| Wavelengths in nm Intensity in mW/cm ² ** | 40 mm version: | | | |
| | 365 | 385 | 395 | 405 |

* typical service life under standard environmental conditions

** measured by Höhle LED sensors for UV meter

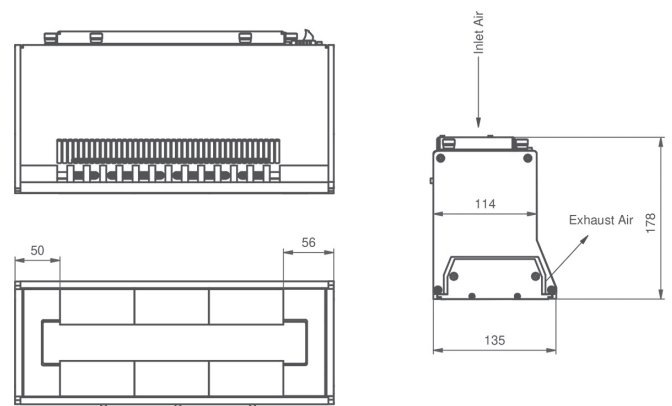

jetCURE LED S with one-sided cooling air outlet